

This document is a simplified reminder of how to drive a personnel lifting platform and, under no circumstances, should be used as a substitute for the instructions manual required by CE Directive 98/37/CE Appendix 1 § 1.7.4, which the operator must have previously read and fully understood and which must be available in the lifting platform's basket. All the safety instructions and advice described in the manual and not repeated in this document must continue to be applied and observed. The operator must have received adequate training and must comply with the prevailing ground traffic regulations.

**BASIC INSTRUCTIONS SHEET**

**120 AETJC**

**TECHNICAL CHARACTERISTICS**

**WEIGHT OF THE LIFTING PLATFORM**

Unladen 6660 kg  
Under nominal load 6860 kg

**BASKET CAPACITY**

2 people, indoors 200 kg

**WEIGHT OF THE ONBOARD EQUIPMENT IN THE BASKET**

1 person in the basket 120 kg  
2 people in the basket 40 kg

**SPEED**

Work speed 0.6 km/h  
Transport speed 5 km/h

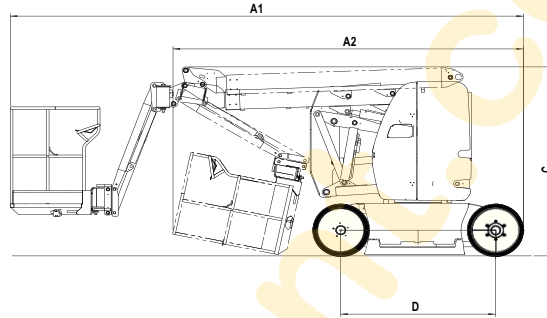
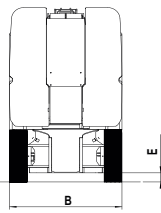

**DIMENSIONS**

A1 = 5477 mm  
A2 = 3740 mm  
B = 1200 mm  
C = 2171 mm  
D = 1650 mm  
E = 104 mm

**GROUND CONTROL & EMERGENCY STATION**

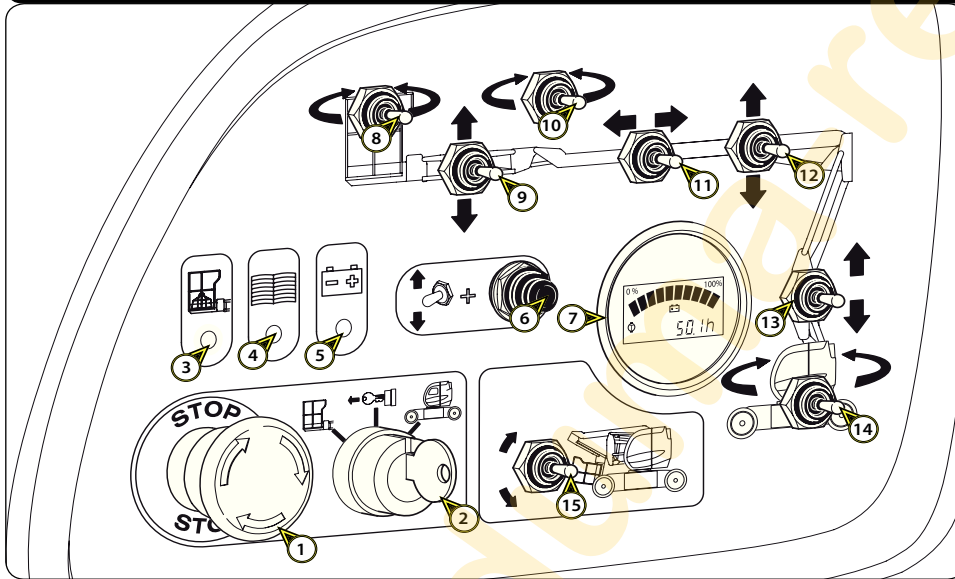

- 1 - EMERGENCY STOP
- 2 - KEY-OPERATED CONTROL SELECTOR SWITCH AT GROUND LEVEL OR IN THE BASKET
- 3 - OVERLOAD LAMP
- 4 - «MACHINE MAINTENANCE» AND VARIATOR FAULTS LAMP
- 5 - «STATE OF BATTERY CHARGE» LAMP
- 6 - «DEAD MAN» BUTTON
- 7 - BATTERY CHARGE INDICATOR AND THE HOUR METER
- 8 - BASKET ROTATION CONTACTOR
- 9 - RAISE AND LOWER CONTACTOR OF THE EXTENSION ARM
- 10 - ROTATION CONTACTOR FOR ROTATED JIB (OPTION)
- 11 - TELESCOPE RETRACTION AND EXTENSION CONTACTOR
- 12 - RAISE AND LOWER CONTACTOR OF THE SUPERIOR ARM
- 13 - RAISE AND LOWER CONTACTOR OF THE INFERIOR ARMS
- 14 - TURRET ROTATION CONTACTOR
- 15 - BASKET TILT CONTACTOR

**BASKET CONTROL STATION**

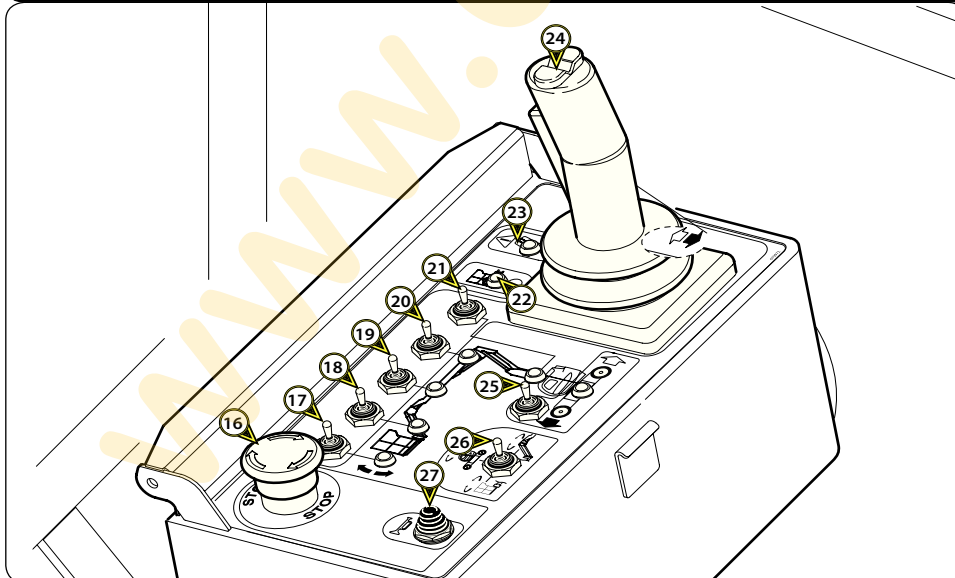

- 16 - EMERGENCY STOP
- 17 - BASKET TILT CONTACTOR
- 18 - PENDULAR ARM LIFTING / LOWERING CONTACTOR
- 19 - TELESCOPE RETRACTION / EXTENSION CONTACTOR
- 20 - SUPERIOR ARM LIFTING / RAISING CONTACTOR
- 21 - INFERIOR ARMS LIFTING / RAISING CONTACTOR
- 22 - OVERLOAD LAMP AND VARIATOR DEFECTS
- 23 - TILT LAMP
- 24 - JOYSTICK
- 25 - TRANSLATION CONTACTOR
- 26 - PENDULAR ARM / TURRET / BASKET ROTATION CONTACTOR
- 27 - BUZZER CONTROL BUTTON



We draw the attention of operators on the risks associated with the use of the lifting platform, including:

- Risk of loss of control.
- Risk of loss of lateral stability of the lifting platform.
- Wearing a safety helmet and a safety harness is REQUIRED when using the lifting platform.



### OPERATING THE PLATFORM

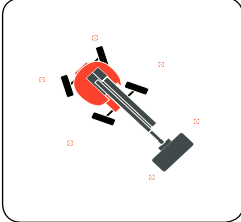

- Before using the platform, check the condition of the ground and the supporting surfaces.
- Do not use the lifting platform, if the wind speed is over 45km/h.
- Remember to mark out the lifting platform's complete operating area.

### TURRET ROTATION BLOCKING

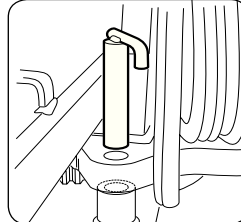

Do not forget to remove it when using the platform.

### ELECTRICAL RISK

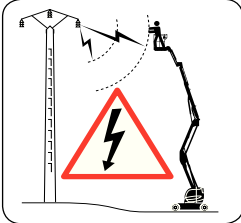

Do not travel or work near any sources of electricity.

### TILT AND OVERLOAD

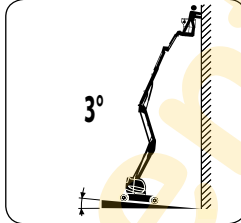

Maximum permissible tilt or slope: 5% or 3°

When the maximum permissible tilt is reached, a buzzer sounds intermittently.

**Overload :**

If the basket is overloaded, a buzzer sounds continuously

### EMERGENCY PROCEDURE

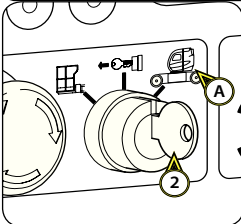

If the operator should be taken ill or should become incapable of manoeuvring the machine, the person on the ground can take over the lifting platform's controls by following the instructions below:

- Move switch 2 to position A to take over control of the lifting platform's movements.
- Proceed to lower the basket.

Pay attention to any structures or items that may be located under the basket.

### MANUAL EMERGENCY PUMP

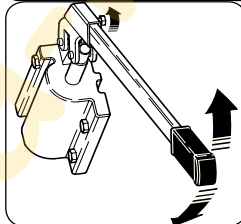

This manual pump allows all movements of the platform to allow a return to the ground in case of failure (see adhesive in the right cover of the turret).

Only to be used in the event of breakdown of the electrical control system.

## DAILY MAINTENANCE

### CHECK THE BATTERY CHARGE

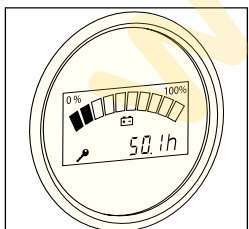

### CHARGE THE BATTERIES

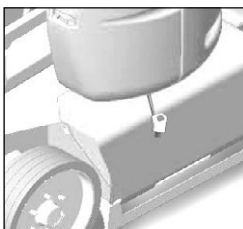

### ELECTROLYTE LEVEL IN THE BATTERIES



### MANIPULATOR BELLOWS STATE

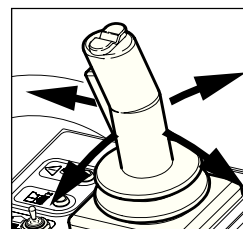

### CHECK THE HYDRAULIC OIL LEVEL

